

Polarizing Microscope
ECLIPSE
E200POL

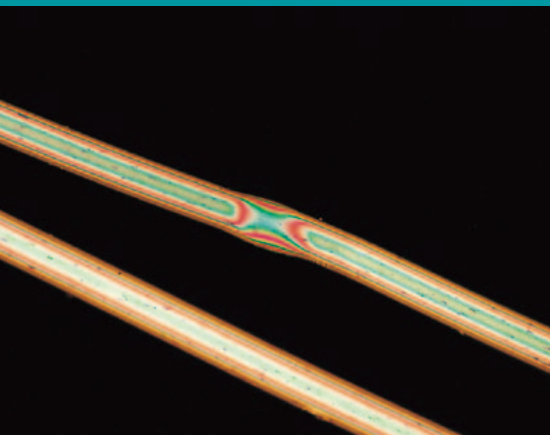

A cost-efficient polarizing microscope incorporating industry-acclaimed CFI60 infinity optics

The E200POL features an extremely compact body that takes up little space on your desk, making this instrument easy to use or transport.

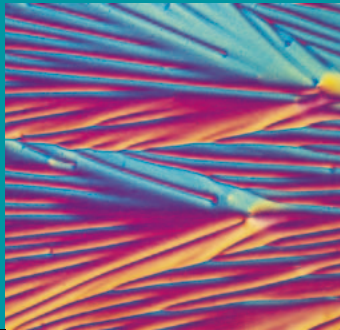
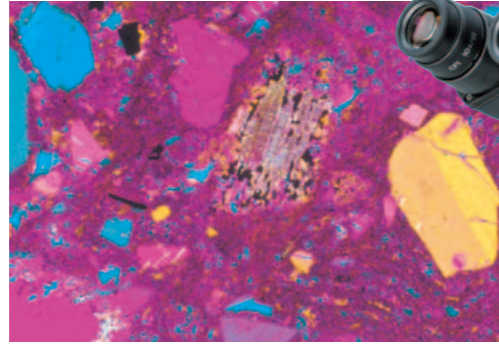

And because the E200POL's design is based on the ECLIPSE E200 biological microscope, it shares the same objectives and uses many of the accessories created for higher-grade ECLIPSE series microscopes, enabling more advanced polarizing microscopy. As you might expect, the E200POL maintains the same operational ease and rigidity as other ECLIPSE series microscopes.

E200POL Standard Set
(Filter is optional)



CFI60 infinity optical system

The CFI60 optical system combines Nikon's renowned CF optical design with infinity optics to overcome the limitations of the traditional infinity design. CFI60 optics provide longer working distances and higher N.A.'s to deliver startlingly clear images at any magnification because chromatic aberrations are corrected over the entire field of view. Nikon CFI optics employ an eco-glass that is manufactured with no harmful substances such as lead and arsenic.



Refocusing stage with upper limit set stop

The unique Refocusing Stage makes specimen handling quicker and easier. The stage can be instantly dropped, just by pushing it down, to exchange specimens. It returns to the original position as soon as the hand is removed.

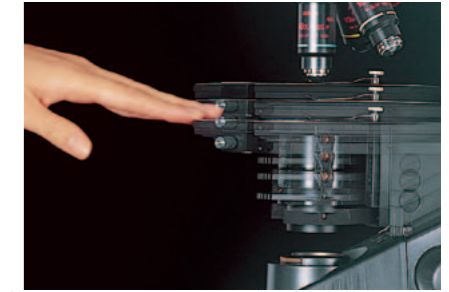

Reversed-type nosepiece

The reversed-type quadruple nosepiece provides more space at the front of the stage to make handling of specimen slides fast and easy. Another advantage of CFI60 objectives is that their increased objective lengths and longer working distances provide more working space around the nosepiece.



Easy lamp replacement

The microscope comes with a unique top-access 6V-30W halogen illuminator. Simply slide open the lens-unit cover to replace the lamp.



Robust, vibration-resistant construction

A solid one-piece casting from arm to base, plus a substantial 188.5mm width, provides greater rigidity and resistance to vibrations. The E200POL is a synthesis of great Nikon optics and solid, vibration-resistant construction.

Comfortable viewing

The Siedentopf-type eyepiece tube—P-TB2 binocular or P-TT3 trinocular—is inclined at 25° to ensure a natural posture for more comfortable viewing.



1/4 Lambda and tint plate

A 1/4 Lambda and first order red tint plate combined on one slider is available to measure and identify the retardation qualities of the specimen.

Rotating stage

This precision, centerable stage features a vernier capable of reading to 0.1° to ensure accurate measurement of the azimuth angles.

Conoscopic observation

The intermediate tube with a Bertrand lens lets you observe conoscopic images. This feature is perfect for uniaxial or biaxial crystal identification, or for evaluation of other optical qualities such as optical signs.

Filters

The daylight-type blue filter assures correct color rendition required for sample evaluation, while the GIF filter is used for retardation measurements and contrast adjustment.

Compensators

Senarmont and quartz wedge compensators are available for quantitative retardation measurement.



Digital Camera System for Microscopes Digital Sight Series

High-definition Color Camera Head DS-Fi2

A 5-megapixel color CCD captures fine-textured images in faithful color.



DS-Fi2

Stand-alone Control Unit DS-L3

The stand-alone controller and its large display monitor enable image capture without a computer. Touch-panel or mouse operation allows setting and control of a camera by simply choosing the "scene mode" icons. Simple measurement functions are also available.



DS-L3

For even greater cost performance, the E200POL Basic Set is also available:

- E2-TB Binocular Tube or E2-TF Trinocular Tube can be selected. Their eyepoint height can be raised 34mm by simply swinging the front part of the tubes up 180°.
- Eyepiece lens: CFI E 10x (F.O.V. 20mm)
- Excellent cost performance



E200POL Basic Set
(Filter is optional)

Dimensional Diagram

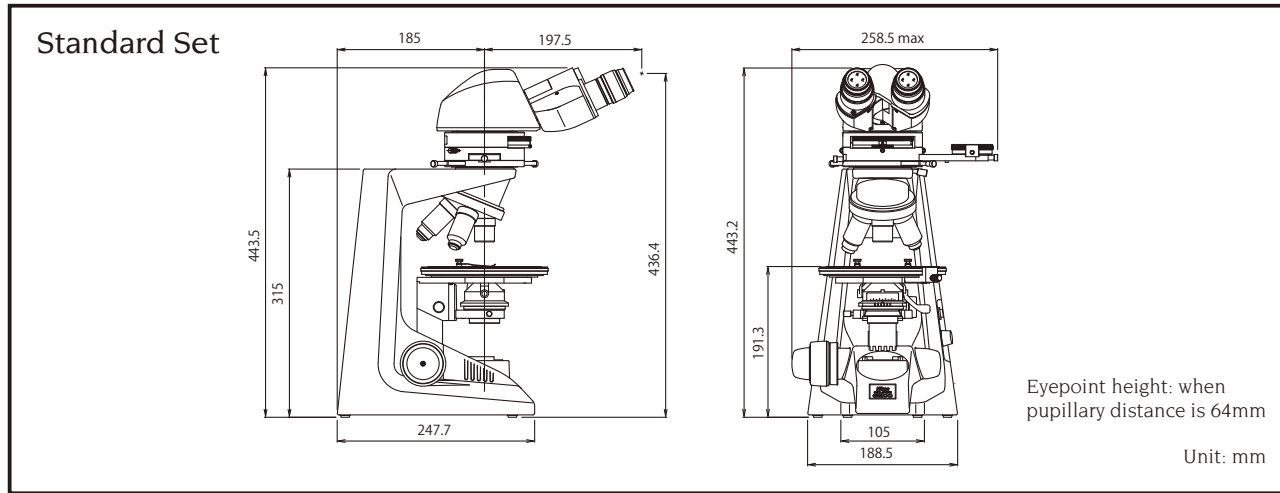

Specifications

Optical system	CFI60 infinity optical system
Eyepiece	Standard set: 10x (F.O.V. 22mm), CM type with 90° crosshair and micrometer scale Basic set: 10x (F.O.V. 20mm)
Eyepiece tube	Standard set: Binocular P-TB2, Trinocular P-TT3 Basic set: Binocular E2-TB, Trinocular E2-TF
Intermediate tube	Built-in focusable Bertrand lens removable from optical path; Built-in analyzer removable from optical path; Conoscopic/Orthoscopic observations switchable; With plate/ compensator slot
Analyzer	360° rotary dial; Minimum reading angle 0.1°
Nosepiece	Quadruple nosepiece fixed to main body

Coarse/fine focusing	Fine: 0.2mm per rotation; Coarse: 37.7mm per rotation; Minimum reading: 2 microns on left-side fine control knob; Coarse motion torque adjustable; Refocusing system incorporated in stage
Stage	160mm ϕ circular graduated stage; 1° increments and vernier reading 0.1°
Illumination	Built-in 6V-30W halogen lamp precentered and prefocused; Continuously variable intensity control; Multi-voltage compliant (100V-240V)
Objective	CFI P Achromat 4x, 10x, 20x, 40x, 100x oil
Condenser	Dedicated strain-free swing-out type
Polarizer	Attachable to bottom of condenser
Compensator	Standard $1/4\lambda$ and tint plate; Quartz wedge or Senarmont compensator can be inserted into intermediate tube slot

Company names and product names appearing in this brochure are their registered trademarks or trademarks.
N.B. Export of the products* in this brochure is controlled under the Japanese Foreign Exchange and Foreign Trade Law.
Appropriate export procedure shall be required in case of export from Japan.

*Products: Hardware and its technical information (including software)

Specifications and equipment are subject to change without any notice or obligation on the part of the manufacturer. September 2013.

©2000-13 NIKON CORPORATION

	WARNING	TO ENSURE CORRECT USAGE, READ THE CORRESPONDING MANUALS CAREFULLY BEFORE USING YOUR EQUIPMENT.
--	----------------	--



NIKON CORPORATION

Shin-Yurakucho Bldg., 12-1, Yurakucho 1-chome,
Chiyoda-ku, Tokyo 100-8331, Japan
phone: +81-3-3216-2375 fax: +81-3-3216-2385
<http://www.nikon.com/instruments/>



ISO 9001 Certified
NIKON CORPORATION
Instruments Company



ISO 14001 Certified
NIKON CORPORATION

NIKON INSTRUMENTS INC.

1300 Walt Whitman Road, Melville, N.Y. 11747-3064, U.S.A.
phone: +1-631-547-8500; +1-800-52-NIKON (within the U.S.A. only)
fax: +1-631-547-0306
<http://www.nikoninstruments.com/>

NIKON INSTRUMENTS EUROPE B.V.

Tripolis 100, Burgenweeshuispad 101, 1076 ER Amsterdam, The Netherlands
phone: +31-20-7099-000 fax: +31-20-7099-298
<http://www.nikoninstruments.eu/>

NIKON INSTRUMENTS (SHANGHAI) CO., LTD.

CHINA phone: +86-21-6841-2050 fax: +86-21-6841-2060
(Beijing branch) phone: +86-10-5831-2028 fax: +86-10-5831-2026
(Guangzhou branch) phone: +86-20-3882-0552 fax: +86-20-3882-0580

NIKON SINGAPORE PTE LTD

SINGAPORE phone: +65-6559-3618 fax: +65-6559-3688

NIKON MALAYSIA SDN. BHD.

MALAYSIA phone: +60-3-7809-3688 fax: +60-3-7809-3633

NIKON INSTRUMENTS KOREA CO., LTD.

KOREA phone: +82-2-2186-8400 fax: +82-2-555-4415

NIKON CANADA INC.

CANADA phone: +1-905-602-9676 fax: +1-905-602-9953

NIKON FRANCE S.A.S.

FRANCE phone: +33-1-4516-45-16 fax: +33-1-4516-45-55

NIKON GMBH

GERMANY phone: +49-211-941-42-20 fax: +49-211-941-43-22

NIKON INSTRUMENTS S.p.A.

ITALY phone: +39-055-300-96-01 fax: +39-055-30-09-93

NIKON AG

SWITZERLAND phone: +41-43-277-28-67 fax: +41-43-277-28-61

NIKON UK LTD.

UNITED KINGDOM phone: +44-208-247-1717 fax: +44-208-541-4584

NIKON GMBH AUSTRIA

AUSTRIA phone: +43-1-972-6111-00 fax: +43-1-972-6111-40

NIKON BELUX

BELGIUM phone: +32-2-705-56-65 fax: +32-2-726-66-45