

Compact  
3D optical  
surface  
profiler



SENSOFAR<sup>®</sup>  
METROLOGY



Compact 3D Profiler

# Compact. Flexible. Powerful.

S lynx is a new non-contact 3D surface profiler designed for use in industry and research. It has been designed as a compact and versatile system. S lynx is able to measure differing textures, structures, roughness and waviness, all across varying surface scales. The S lynx's versatility makes it appropriate for a broad range of high-end surface measurement applications. Ideal performance is guaranteed by Sensofar's proprietary 3-in-1 measurement technology, and complemented by the incredibly intuitive operation of the system with the associated SensoSCAN software.

## Applications

- | Automotive
- | Consumer electronics
- | Energy
- | LCD
- | Materials science
- | Microelectronics
- | Micromanufacturing
- | Micropaleontology
- | Optics
- | Tooling
- | Semiconductors
- | Watch manufacturing

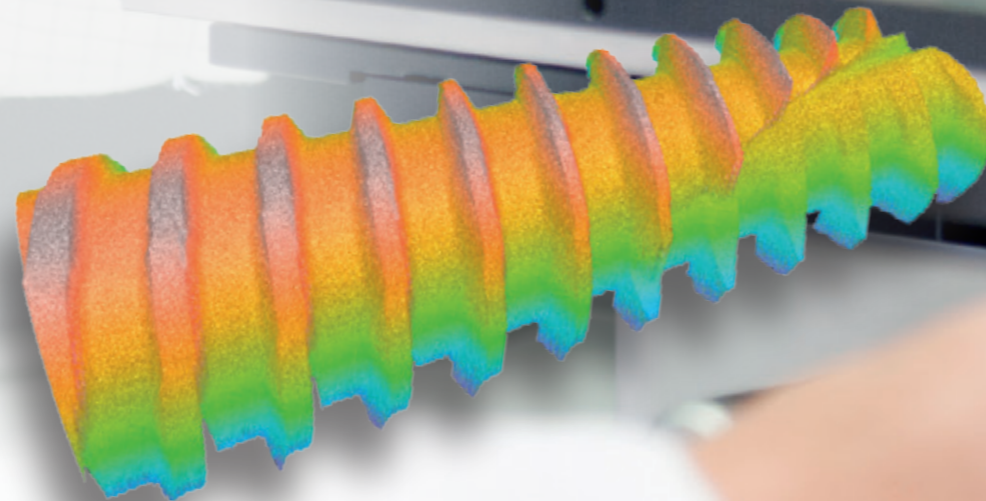

# Why 3-in-1 technologies?

Single-technology systems are subject to a lack of versatility. When confronted with measurement tasks that push the boundaries of their physics-based limitations, the only option is to manipulate the measurement parameters to favor the requisite result. However, favoring either speed, or resolution or accuracy usually means sacrificing one or both of the others, and the user is thus confronted with some sort of compromise in the data acquisition.

With Sensofar's 3-in-1 approach – as found in the S line of measurement systems – a single click in software switches the system to the best technique for the task at hand. The 3 measurement techniques found in the S lynx sensor head – confocal, vertical scanning interferometry & focus variation – thus each contribute critically to the versatility of the system, help minimize undesirable compromises in the data acquisition, and together provide Sensofar's class-leading surface measurement performance.

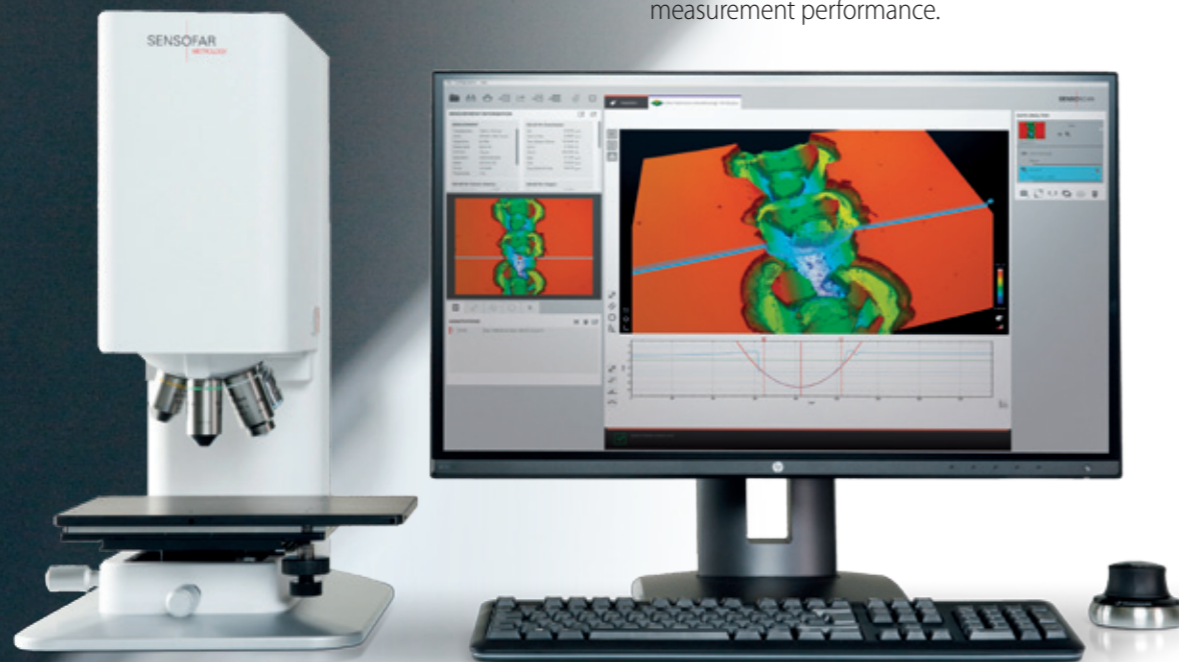

## Confocal

Confocal profilers have been developed for measuring smooth to very rough surfaces. Confocal profiling provides the highest lateral resolution that can be achieved by an optical profiler. Thus, spatial sampling can be reduced to 0.01  $\mu\text{m}$ , which is ideal for critical dimension measurements. High NA (0.95) and magnification (150X) objectives are available to measure smooth surfaces with steep local slopes over 70° (for rough surfaces up to 86°). The proprietary confocal algorithms provide the unique vertical repeatability on the nanometer scale.

## Interferometry

White-light vertical scanning interferometry (VSI) is a widely used and powerful technique for measuring surface characteristics such as topography or transparent film structure. It is best suited for measuring smooth to moderately rough surfaces, and provides nanometer vertical resolution regardless of the objective's NA or magnification.

## Focus Variation

Focus Variation is an optical technology that has been developed for measuring the shape of large rough surfaces. This technology is based on Sensofar's extensive expertise in the field of combined confocal and interferometric 3D measurements, and is specifically designed to complement confocal measurements at low magnification. Highlights of the technology include high slope surfaces (up to 86°), highest measurement speeds (mm/s) and large vertical range. This combination of measurement capabilities is mainly used for tooling applications.

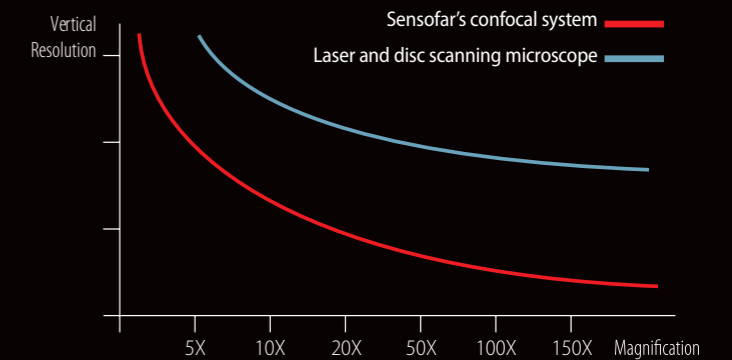

## Confocal with no moving parts

The confocal scanning technique implemented in Sensofar's systems utilizes a patented microdisplay scanning technology. The microdisplay is based on ferroelectric liquid crystal on silicon (FLCoS) technology, creating a rapidly switching device with no moving parts that makes the scanning of confocal images fast, reliable and accurate. Due to the microdisplay and the associated algorithms, Sensofar's confocal technique yields a class-leading vertical resolution, better than other confocal approaches and even better than laser scanning confocal systems. All without filtering the data.

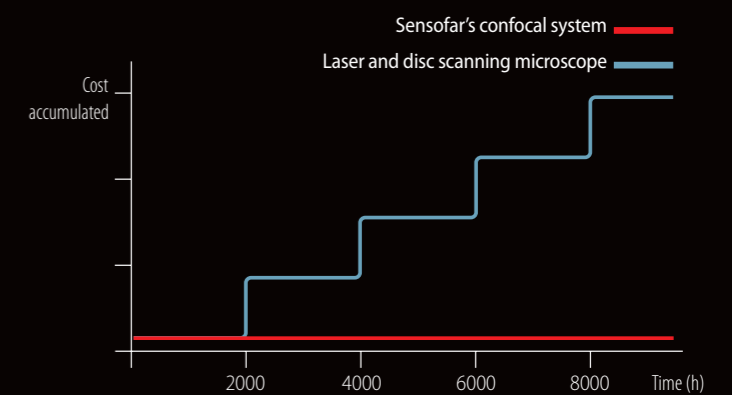

## No maintenance

Alternative confocal microscopes use mirror scanning heads or a scanning disc approach. Both are moving mechanisms that can limit lifetime and that certainly degrade pixel dithering at high magnifications. Sensofar's approach with a microdisplay has no moving parts, yielding a very stable system with unlimited lifetime and zero consumables.

# Automated acquisition

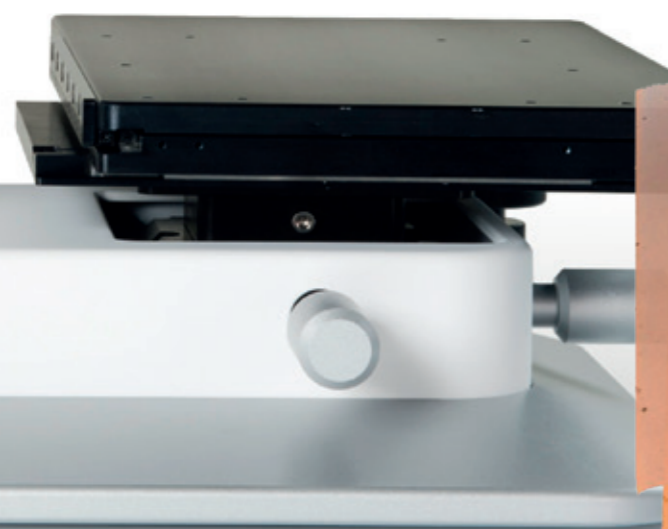

## 3D auto function

This new feature vastly simplifies the data acquisition process. By placing the sample on the desired position, focusing it and selecting 3D auto function, the SensoSCAN software automatically determines the correct illumination (light) and the appropriate measurement range, and then performs the chosen measurement type. A quality result can thus be obtained within just a few seconds.

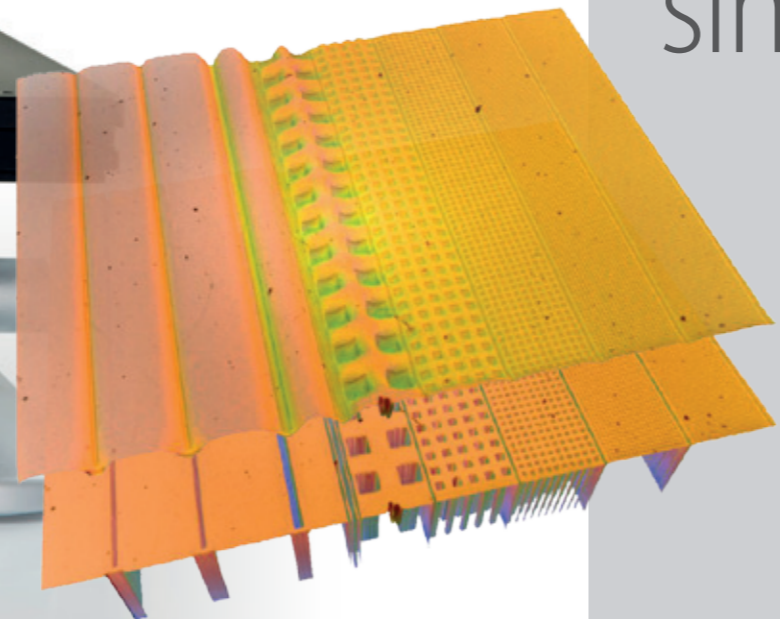

## Live image options

SensoSCAN software now displays the confocal live image as you have never seen it before. Quality and speed have been improved to yield a frame rate of 9 fps (frames per second) for confocal images and 30 fps for bright field images. Together with the other live image options, samples viewing is now significantly more accessible and flexible.

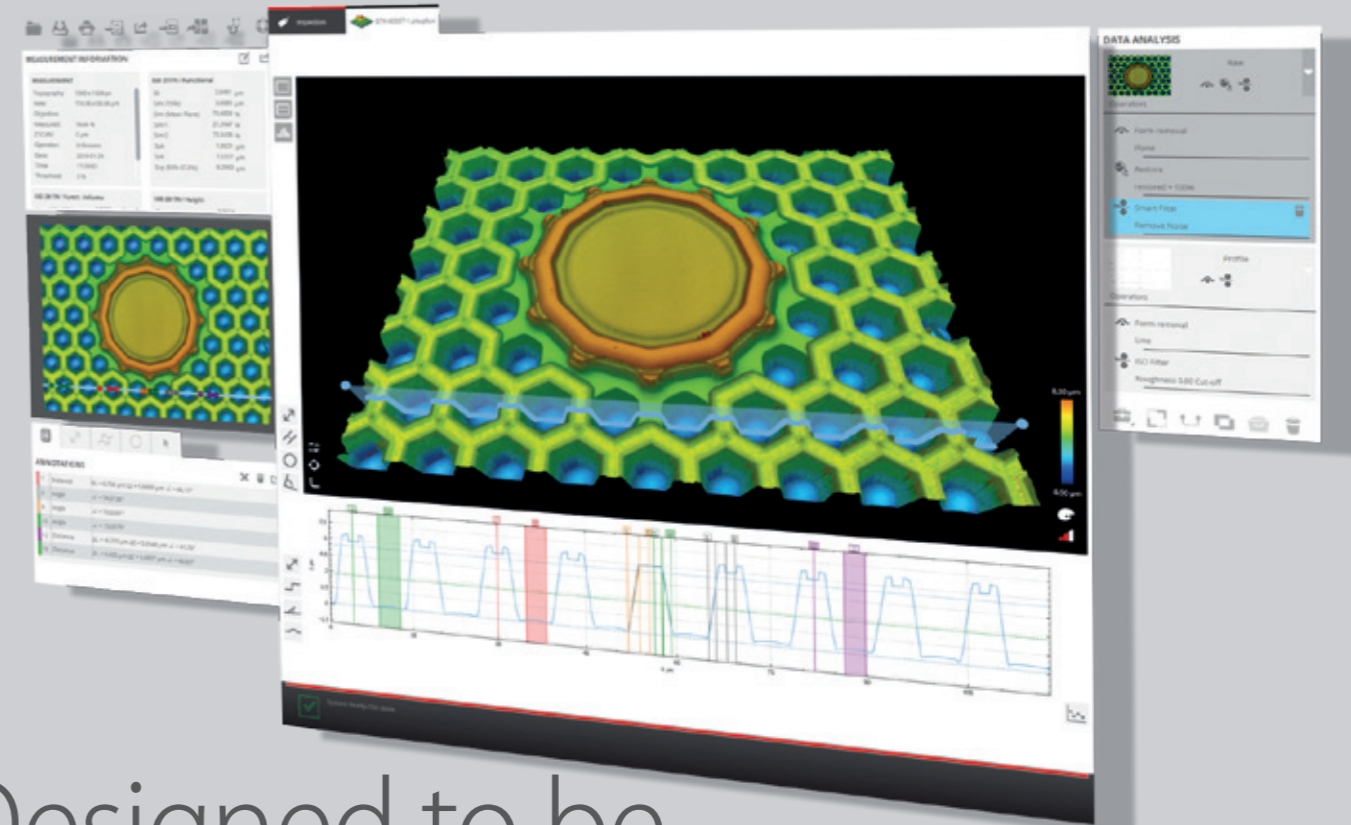

# Designed to be simple and easy to use

## Guided interface

When switching between measurement techniques (confocal, interferometric or focus variation), the system is automatically optimized and settings parameters are trimmed to those permissible for the chosen measurement type (image, 3D, thickness or profile). Visual distinction between the different measurement techniques is provided in SensoSCAN through the use of color schemes. At the same time, the user is guided through the interface by the use of an intuitive structure and descriptive icons.

## Multiple powerful acquisition settings

Numerous acquisition parameters can be adapted to best suit the intended measurement. For example, various autofocus settings help to reduce the acquisition time, multilevel light strategies help improve the illumination of complex 3D structures and selectable Z-scan options also provide an opportunity to optimize the acquisition for varying 3D surfaces. All acquisition parameters can be saved as a template for re-use individually (SMR) or for repetitive measurements (MMR).

## ISO parameters

SensoSCAN is compliant with ISO 25178. A complete selection of ISO 3D areal surface texture parameters is available: height, spatial, hybrid, functional and volumetric parameters.

2D and 3D surface texture parameters

MEASUREMENT INFORMATION	
<b>MEASUREMENT</b>	<b>ISO 25178 / Functional</b>
Topography: 1366 x 1024 µm	Sk: 21.764 µm
Height: 871.21 x 684.43 µm	Sm: 0.796 µm
Objective: 40x 0.10 NA	Sp: 20.661 µm
Magnification: 100 %	Sp1: 12.084 µm
Z Scale: 81.9875 µm	Sp2: 8.576 µm
Operator: Administrator	Sp3: 3.089 µm
Date: 2016-05-25	Sp4: 4.088 µm
Time: 15:02:51	Sp5 (ISO 25178): 11.489 µm
Threshold: 1 %	
<b>ISO 25178 / Area, Volume</b>	<b>ISO 25178 / Height</b>
Area (1366x1024): 1399732 µm²	Sa: 6.2887 µm²
Area (Z-Pro): 64790 µm²	Sms: 0.8961 µm²
Vol (1366x1024): 84817 µm³	Vmc: 0.0089 µm³
Vol (Z-Pro): 61738 µm³	Vvc: 0.0118 µm³
Vol (1366x1024): 81738 µm³	Vvc: 0.0118 µm³
Vol (Z-Pro): 61738 µm³	Vvc: 0.0118 µm³

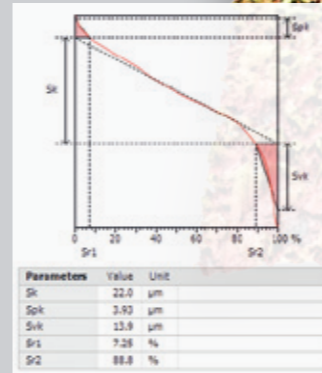
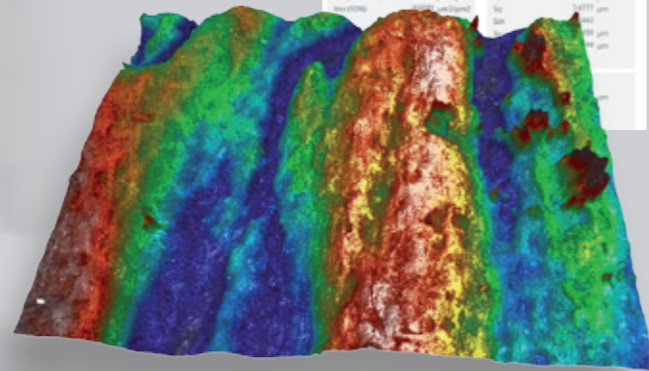

Tribology, lubrication and grinding parameters

## Sequential operators

A comprehensive set of operators provides the opportunity to retouch data points, restore non-measurable data, remove form (plane, sphere, polynomial), apply a range of filters and/or generate alternative layers by cropping, subtracting or extracting a profile. It is also possible to create analysis templates to apply pre-determined filter and operator configurations to repeated measurements.

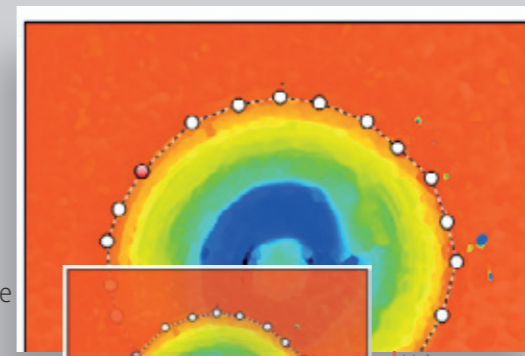

Volume

Parameter	Unit	Value
Surface	µm²	94282
Volume	µm³	288207
Max. depth/height	µm	206
Mean depth/height	µm	44.3

# It is time to play...

## Interactive analysis tools

3D and 2D interactive views provide multiple scaling, display and render options. A comprehensive suite of tools for preliminary examination and analysis of 3D or 2D measurements is provided. Dimensions, angles, distances, diameters can be measured and features highlighted with new critical dimensions tools. All of these features make the new SensoSCAN an ideal software package for a broad range of analysis tasks. For applications requiring a more complete analysis suite, advanced analysis software packages are optionally available, SensoMAP and SensoPRO LT.

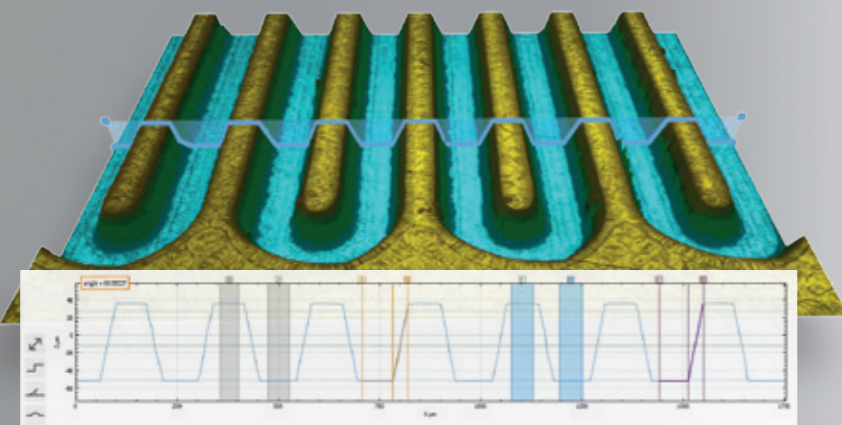

Step height and angle

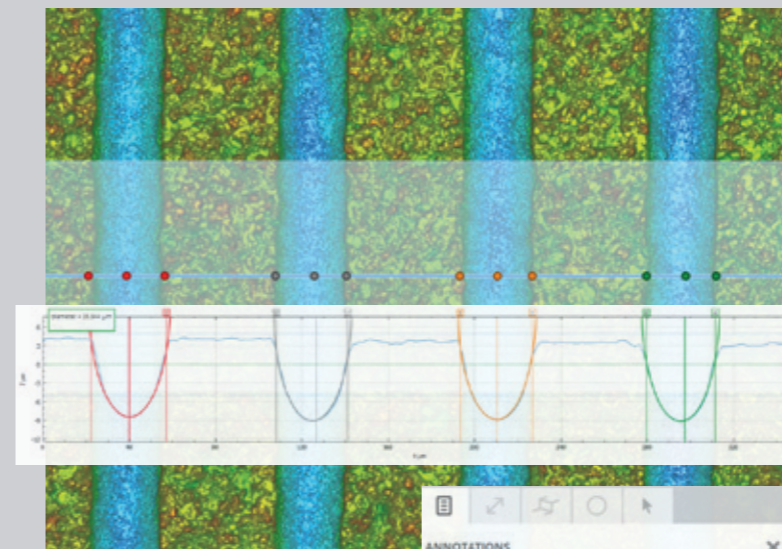

Form and contour

ANNOTATIONS	
1	Circle Dxy = 38.244 µm Avg = 1148.87 µm²
2	Circle Dxy = 36.262 µm Avg = 1038.84 µm²
3	Circle Dxy = 36.474 µm Avg = 1046.84 µm²
4	Circle Dxy = 35.844 µm Avg = 1014.71 µm²

... and get your results!

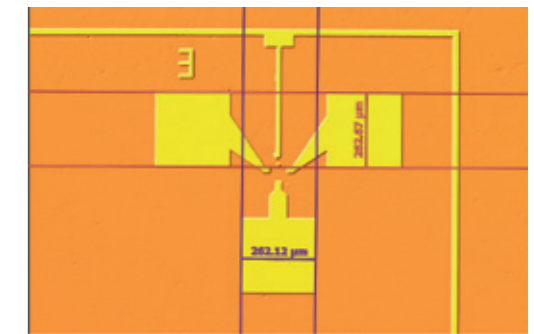

## Analysis report

Obtain a clear and well-structured report for each measurement, showing the 3D data, a 2D profile and all the ISO parameters. SensoSCAN can also export data in to \*.csv and \*.dat, and graphics into \*.png, \*.tiff or \*.jpg formats.

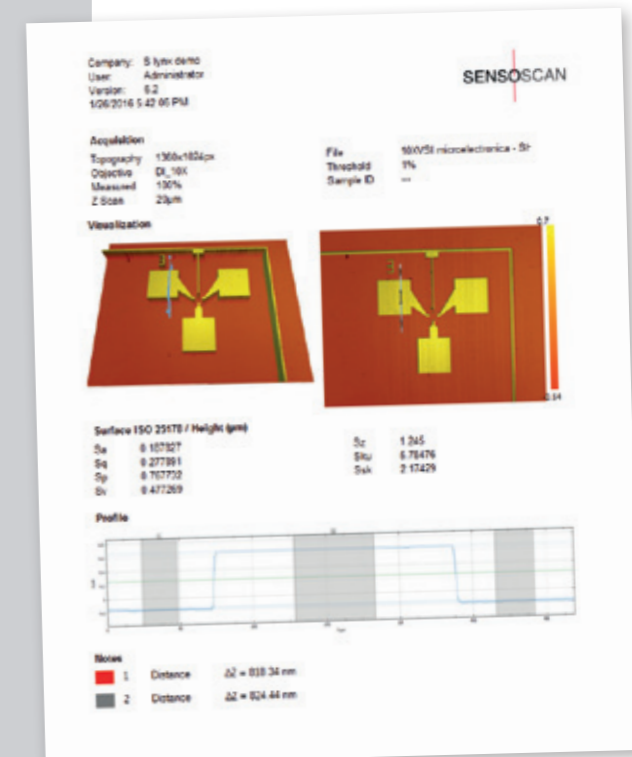

Its incredibly compact design with integrated sensor head and controller results in a small footprint and makes for a robust, and reliable system that is easy to install. Vibration isolation pads give the system high stability - in most cases no vibration isolation table is needed.

# Hardware

## Large range of objectives

The S lynx uses premium CF60-2 Nikon objectives that exhibit the largest working distance for each NA. Over 30 objectives are available. Combined with an encoded nosepiece that recognizes a change of objective and switches software automatically.

## Adaptable column

Sensofar has developed a 4-position column that allows up to 150 mm of height adjustment. Flexible options are designed to avoid restrictions between samples with differing heights.

## Movement system

The S lynx positioning is composed of a motorized Z stage with 40 mm of travel range and high position accuracy, and a manual XY stage with 150 mm x 100 mm of travel range. A tip-tilt goniometer, resulting in a point of rotation that remains in focus, completes the movement system.



## Objectives

MAG	Brightfield							Interferometric				
	2.5X	5X	10X	20X	50X	100X	150X	5X	10X	20X	50X	100X
NA	0.075	0.15	0.30	0.45	0.80	0.90	0.95	0.13	0.30	0.40	0.55	0.70
WD (mm)	6.5	23.5	17.5	4.5	1.0	1.0	0.2	9.3	7.4	4.7	3.4	2.0
FOV <sup>1</sup> (µm)	7016x5280	3508x2640	1754x1320	877x660	351x264	175x132	117x88	3508x2640	1754x1320	877x660	351x264	175x132
Spatial sampling <sup>2</sup> (µm)	5.16	2.58	1.29	0.65	0.26	0.13	0.09	2.58	1.29	0.65	0.26	0.13
Optical resolution <sup>3</sup> (µm)	2.23	1.11	0.55	0.37	0.21	0.18	0.17	2.58	1.29	0.65	0.25	0.20
Measurement time <sup>4</sup> (s)	>3s							>3s				

Vertical resolution <sup>5</sup> (nm)	Confocal							VSI				
	-	75	25	8	3	2	1	1				
Maximum slope <sup>6</sup> (°)	-	8	14	21	42	51	71	8	14	21	25	42

Focus variation	
Min. measurable roughness	Sa > 10 nm
Maximum slope <sup>6</sup> (°)	up to 86°

**1** Maximum field of view with 2/3" camera and 0.5X optics. **2** Pixel size on the surface. **3** L&S: Line and Space, half of the diffraction limit according to the Rayleigh criterion. Values for white LED. Spatial sampling could limit the optical resolution for interferometric objectives. **4** For brightfield objectives, 21 scanning planes (confocal). **5** System noise measured as the difference between two consecutive measurements of a calibration mirror placed perpendicular to the optical axis. **6** On smooth surfaces, up to 86° on rough surfaces. Other objectives are available.

## System specifications

Measurement array	1360 x 1024 pixels
LED light source	white (lifetime 40000 h)
XY travel range	150 mm x 100 mm (6" x 4")
XY stage	250 mm x 200 mm (10" x 8")
Manual goniometer	+/- 3°
Maximum sample weight	10 kg (22 lbs)
Sample height	up to 150 mm (6") (adaptable)
Z travel range	40 mm (1,6")
Z stage linearity	<0.5 µm/mm
Z stage resolution	2 nm
Max. vertical scanning range	Focus Variation 25 mm; Confocal 36 mm; VSI 7 mm
Step height repeatability	< 3 nm
Sample reflectivity	0.05 to 100 %
Display resolution	0.01 nm
Computer	Latest INTEL processor; 2560 x 1440 pixel resolution (27")
Operating system	Microsoft Windows 8, 64bit
System	Line Voltage 100-240 V AC; frequency 50/60 Hz single phase
Environment	Temperature 10-35°C; Humidity <80 % RH; Altitude <2000 m

## Dimensions

Weight: 26 kg (57 lbs)

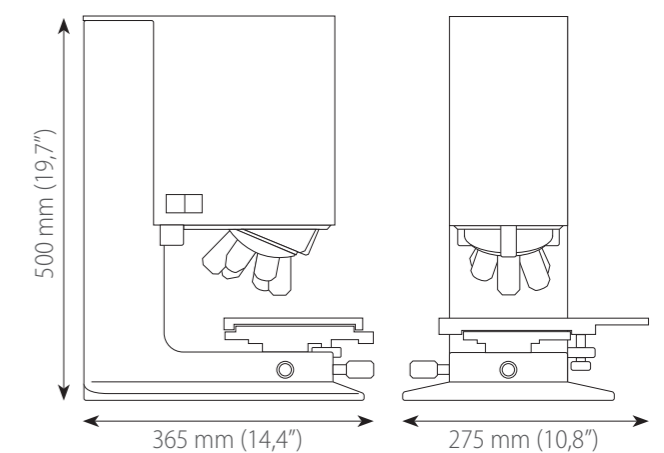

## Software

User Management rights	Administrator, supervisor, advanced operator, operator
Acquisition technologies	Confocal, VSI and Focus Variation
Measurement types	Image, 3D, 3D thickness, profile and coordinates
Advanced Software Analysis	SensoMAP and SensoPRO LT (optional)



SENSOFAR is a leading-edge technology company that has the highest quality standards within the field of surface metrology.

Sensofar Metrology provides high-accuracy optical profilers based on confocal, interferometry and focus variation techniques, from standard setups for R&D and quality inspection laboratories to complete non-contact metrology solutions for in-line production processes. Sensofar Metrology offers technology that enables our customers to achieve real breakthroughs, particularly in semiconductor, precision optics, data storage, display devices, thick and thin film and materials testing technology fields.

The Sensofar Group has its headquarters in Barcelona also known as Spain's technological heart. The Group is represented in over 20 countries through a global network of partners and its own offices in Asia and the United States.



SENSOFAR®  
METROLOGY

HEADQUARTERS  
**SENSOFAR-TECH, SL**  
Parc Audiovisual Catalunya  
Ctra. BV-1274, KM 1  
E-08225 Terrassa (Spain)  
Tel. (+34) 93 700 14 92  
Fax (+34) 93 786 01 16  
info@sensofar.com  
[www.sensofar.com](http://www.sensofar.com)

SALES OFFICES  
**SENSOFAR USA**  
8655 E Via De Ventura  
Suite G168  
Scottsdale, AZ 85258  
T: 1 800 530 3097  
F: 1 419 745 1506  
info@sensofarusa.com  
[www.sensofarusa.com](http://www.sensofarusa.com)

**SENSOFAR ASIA**  
Room 102, Building C, No. 838  
GUANGJI Road, HONGKOU District  
Shanghai, 200434  
T: +86 021 51602735  
F: +86 021 61400059  
info.asia@sensofar.com  
[www.sensofar.com](http://www.sensofar.com)